

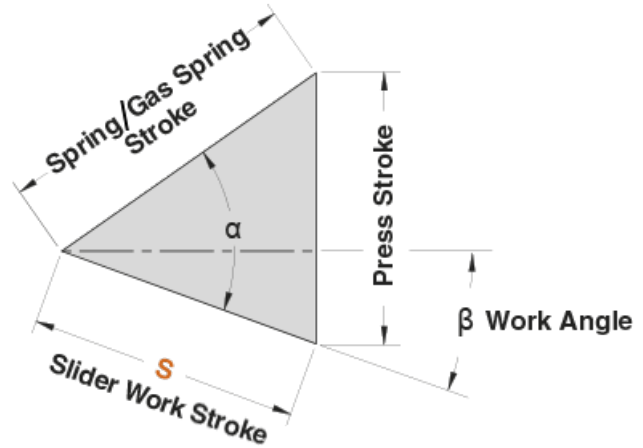

1. CAM DIAGRAM

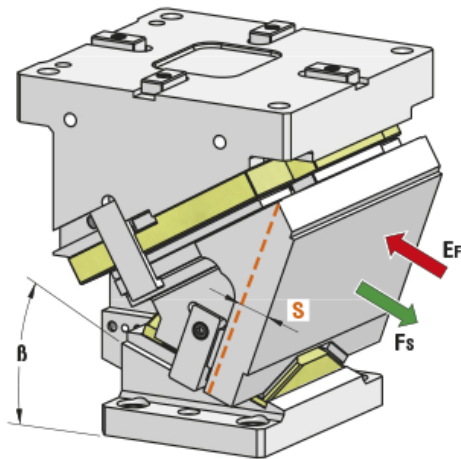

OMCR CODE	Work Angle β	Slider Work Stroke S (mm)	Press Stroke (mm)	Spring / Gas Spring Stroke (mm)	$\alpha - \beta$	α
CHR300.00	0°	38,57	45,96	60	50°	50°
CHR300.05	5°	42,59	46,14	60	45°	50°
CHR300.10	10°	46,67	46,67	60	40°	50°
CHR300.15	15°	50,88	47,58	60	35°	50°
CHR300.20	20°	55,30	48,91	60	30°	50°
CHR300.25	25°	60,00	50,71	60	25°	50°
CHR300.30	30°	65,10	53,07	60	20°	50°
CHR300.35	35°	70,75	56,11	60	15°	50°
CHR300.40	40°	77,13	60,00	60	10°	50°
CHR300.45	45°	84,53	65,00	60	5°	50°
CHR300.50	50°	79,34	60,78	51	0°	50°
CHR300.55	55°	88,92	72,84	51	0°	55°
CHR300.60	60°	102,00	88,33	51	0°	60°



2. WORK FORCE DISTRIBUTION (kN) FOR 1 MILLION CYCLES

The following diagrams illustrate the maximum possible ranges of camforce applicable in several portions of the work area but always working in the exact direction of slider work stroke. If several forces are applied simultaneously on the work area, their common center has to be specified and compared with the tabular infos. The sum of all forces has to be lower than the corresponding tabular value.

F_s

Max Work Force with shoulder

F_k
k

Max Work Force with fitting keys

Assembly with shoulder

		WIDTH				
		60	60	60	60	60
$\beta=0^\circ\div 60^\circ$		60	60	60	60	60
HEIGHT	55	99	183	403	183	99
	50	132	248	521	248	132
	55	113	198	470	198	113

Assembly with fitting keys

		WIDTH				
		60	60	60	60	60
$\beta=0^\circ\div 60^\circ$		60	60	60	60	60
HEIGHT	55	45	82	201	82	45
	50	59	111	260	111	59
	55	51	89	235	89	51